



Boxart: Seweryn Fleischer

PZL W-3A SOKÓŁ

Czech Air Force

SCALE 1/48

The PZL W-3 Sokół (Falcon) is a medium-size, twin-engine, multipurpose helicopter developed and manufactured by Polish helicopter company PZL-Świdnik. It was the first helicopter entirely designed and produced in Poland. Design work was performed by an in-house team led by aeronautical engineer Stanisław Kamiński and next by engineer Cezry Kamiński. On 16 November 1979, the Sokół conducted its maiden flight. Following an intensive test programme, type certificated for the helicopter was received from aviation authorities in Poland, Russia, the United States and Germany. During May 1993, certification of the Sokol to Federal Aviation Administration (FAA) FAR Part 29 standards was granted; it was followed by the receipt of German certification during December of that year. During 1995, low rate production of the Sokół commenced. In June 1996, the 100th Sokół was completed by the company. The Sokół has been offered in a number of diverse variants and is capable of performing a typical range of helicopter, missions, including passenger transport, troop transport, attack, VIP, cargo, EMS, medevac, firefighting and search and rescue. When used in maritime environments, the rotorcraft is typically outfitted with floats, a transponder, a global positioning system navigation system, night-vision equipment, and a Lucas winch. W-3A is a basic military transport variant. In 1996 the Czech Air Force acquired 11 helicopters of this type. Some of Czech W-3A was modified to EMS/SAR services.

Special thanks for Mr Adam Pękala, Tomasz Bilkiewicz and Jan Tomek for their vast knowledge and help in the production of this model.

PZL W-3 Sokół to śmigłowiec wielozadaniowy produkowany w zakładach PZL-Świdnik. Jest to zarazem pierwszy śmigłowiec polskiej konstrukcji, który trafił do seryjnej produkcji. Zaprojektowany przez zespół pod kierownictwem inż. Stanisława Kamińskiego, a następnie inż. Cezarego Kamińskiego. Oblot prototypu miał miejsce 16 listopada 1979 roku. Rozpoczęcie produkcji seryjnej nastąpiło w 1984 roku, a pierwszy seryjny Sokół odbył swój dziewiczy lot 29 listopada 1986. Początkowo zakładano, że głównym odbiorcą śmigłowca będzie lotnictwo ZSRR, jednak pomimo prób wprowadzenia Sokoła do służby w Aeroflot zakończyły się ostatecznie niepowodzeniem. Do końca 1993 roku śmigłowiec uzyskał certyfikaty niemieckie oraz amerykańskie (FAA). Ogółem do końca 2018 roku zbudowano 178 egzemplarzy W-3 Sokół różnych wersji. Śmigłowiec W-3 Sokół był produkowany w wariantach podstawowym transportowym oraz wielu odmianach specjalistycznych, tak cywilnych jak i wojskowych – pasażerskiej, VIP, EMS, medevac (ewakuacyjna), SAR, pożarniczej oraz bliskiego wsparcia pola walki. W 1996 Czeskie Siły Powietrzne w zamian za 10 używanych samolotów Mig-29 otrzymały od Polski 11 nowych śmigłowców W-3A Sokół. W-3A jest podstawową wersją transportową, jednak część z nich została dostosowana do pełnienia zadań EMS/SAR i wyposażona w specjalistyczny sprzęt medyczny oraz ratowniczy.

Specjalne podziękowania za pomoc w opracowaniu modelu oraz konsultacje merytoryczne panom Adamowi 'Adamski' Pękale, Tomaszowi Bilkiewiczowi oraz Janowi Tomek.

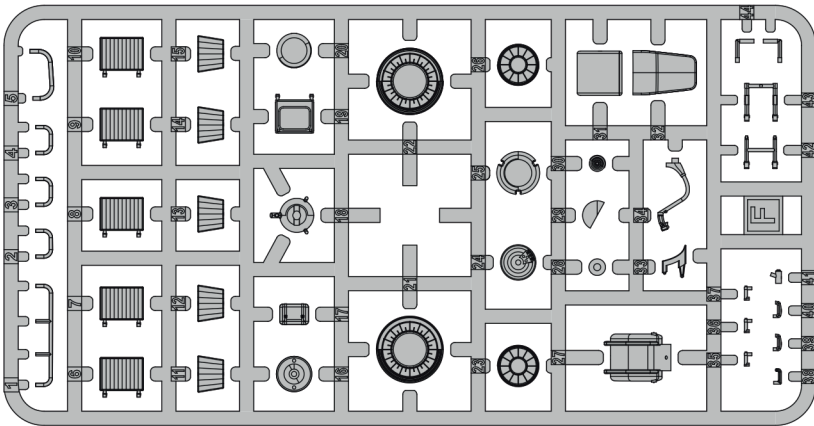
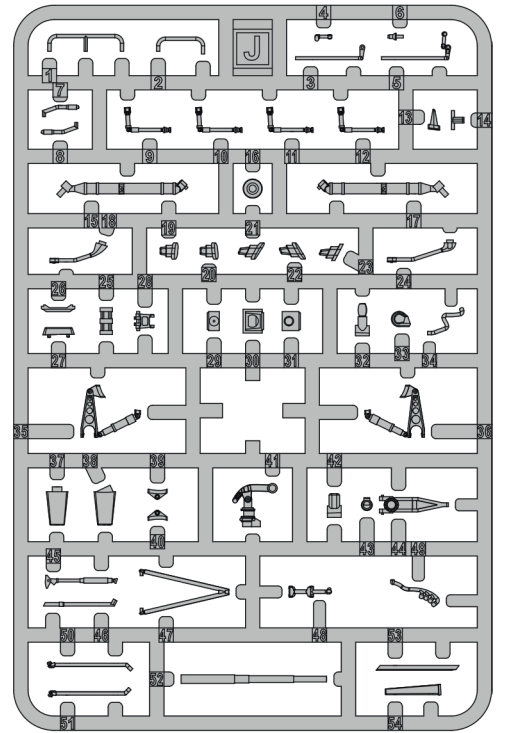
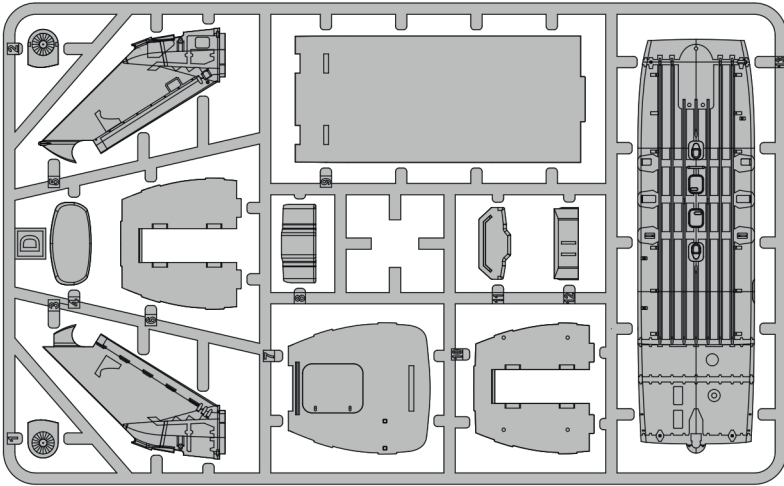
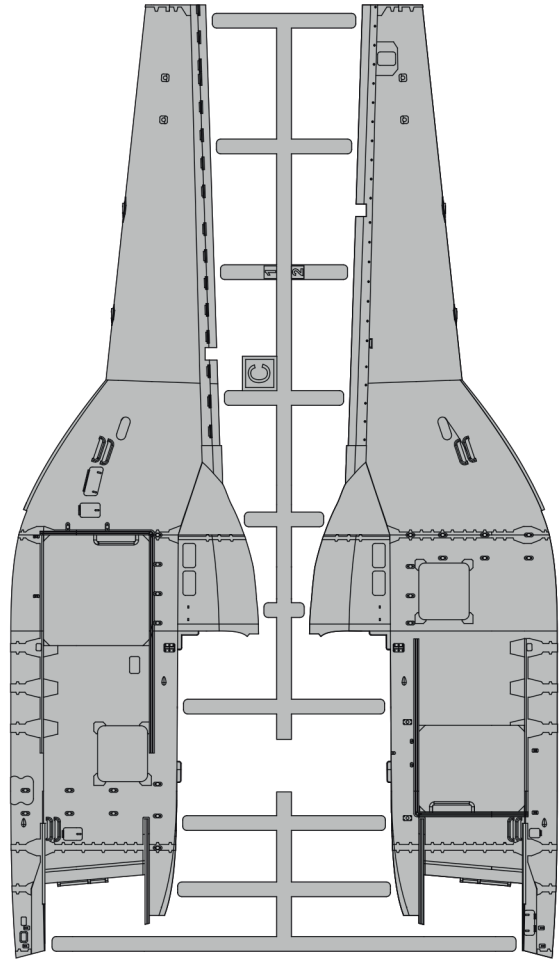
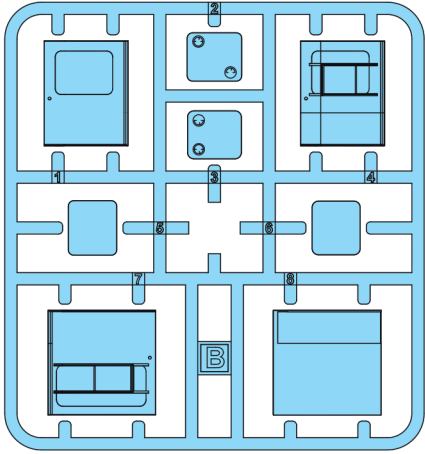
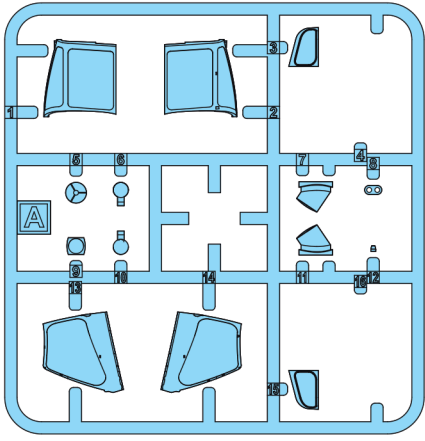

x2

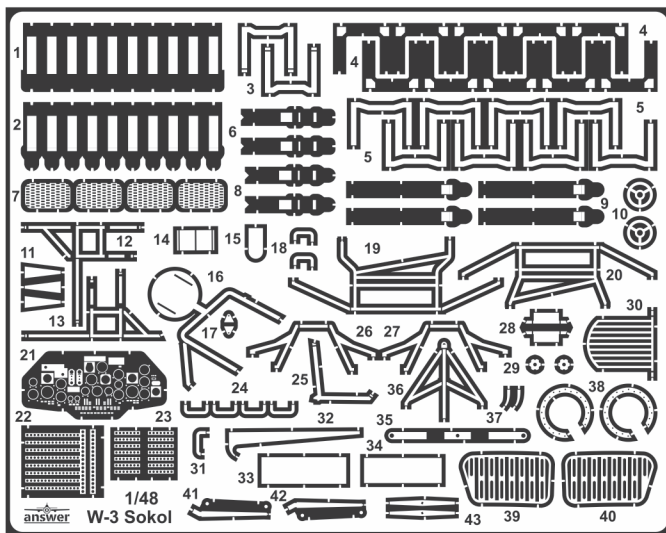
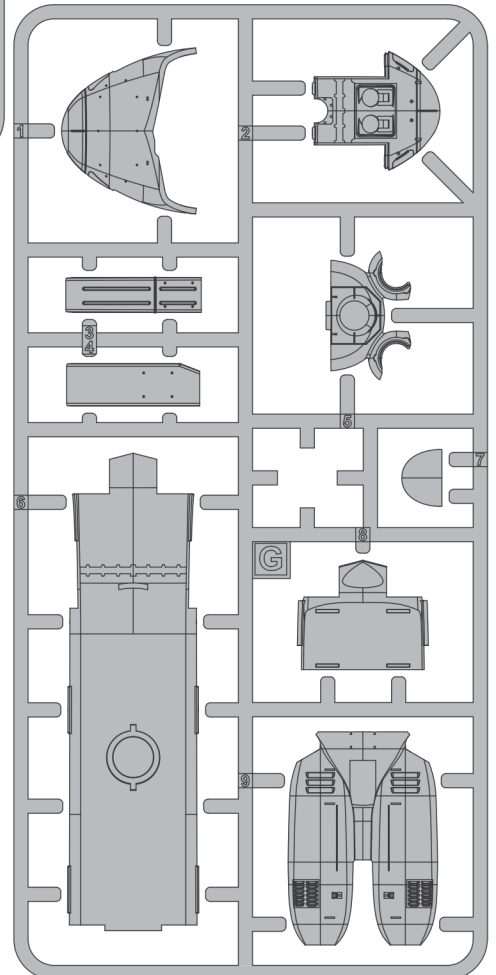
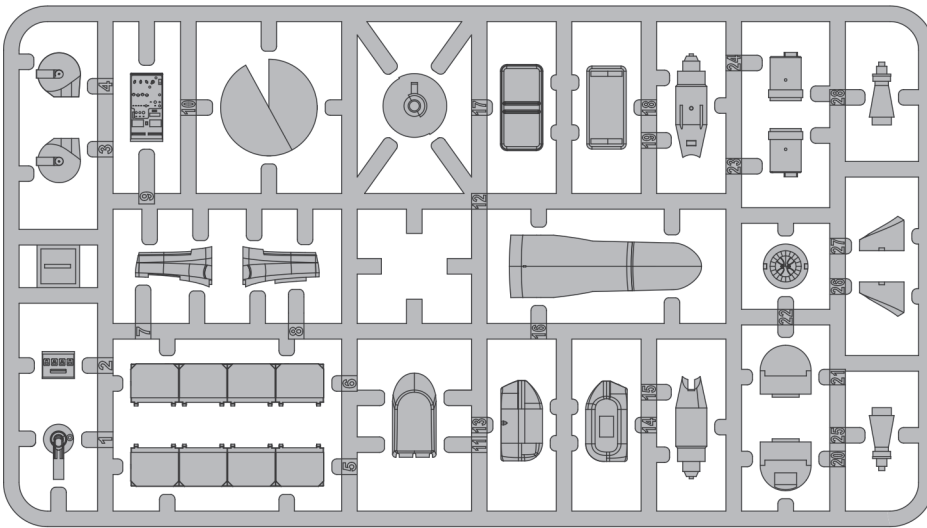
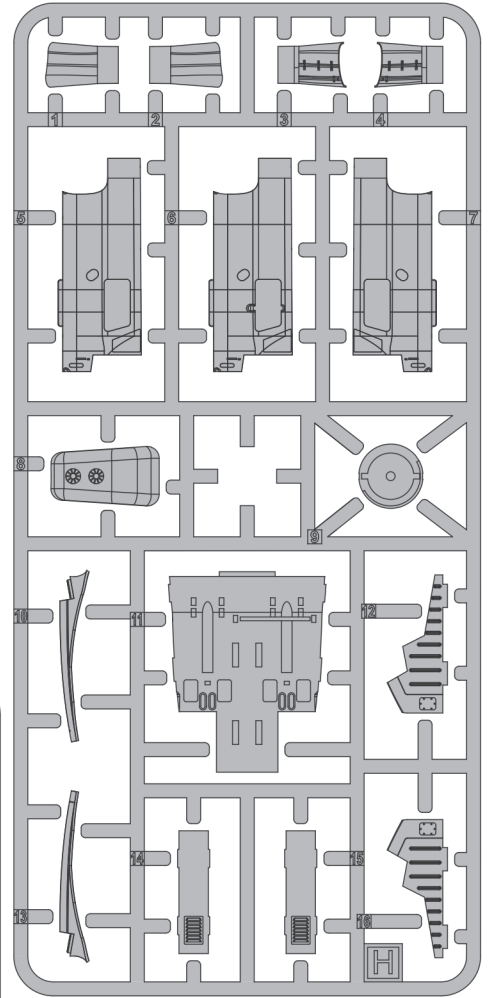
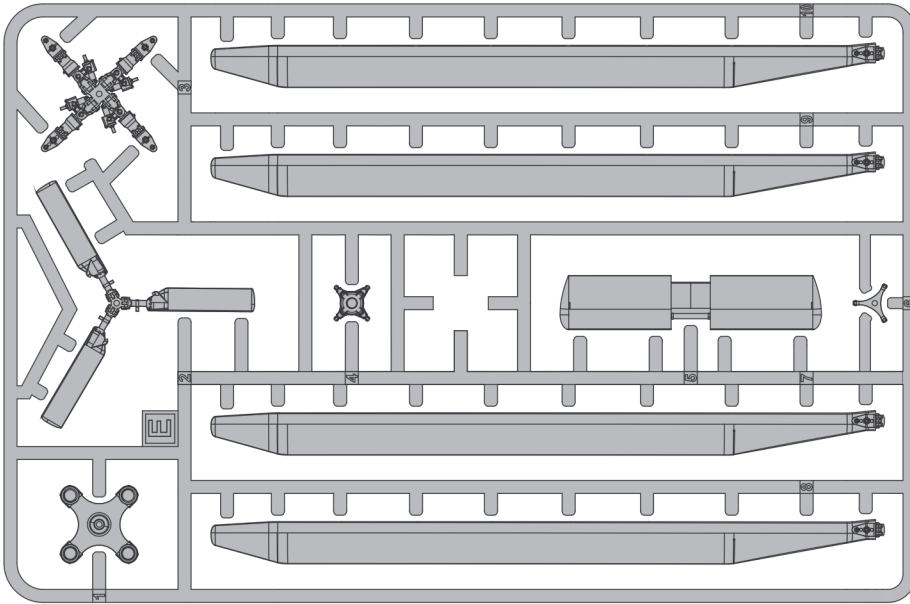

1x2

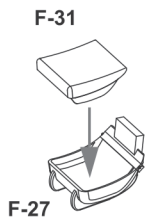

2x2

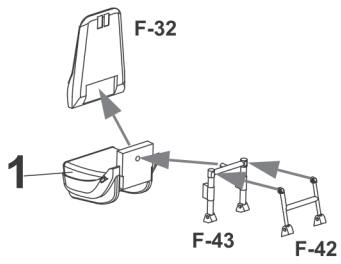

3x2

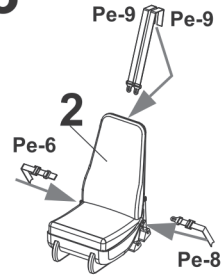

4

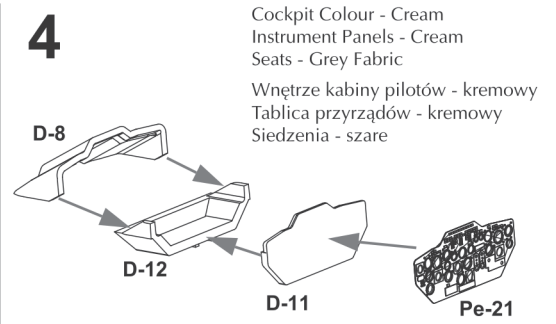

5

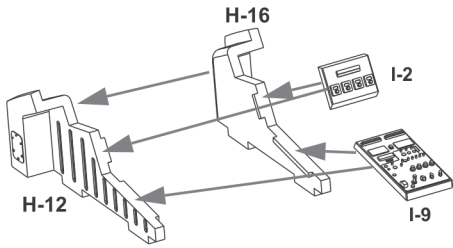

6

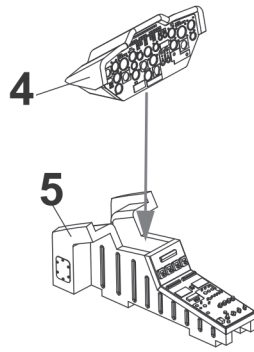

7

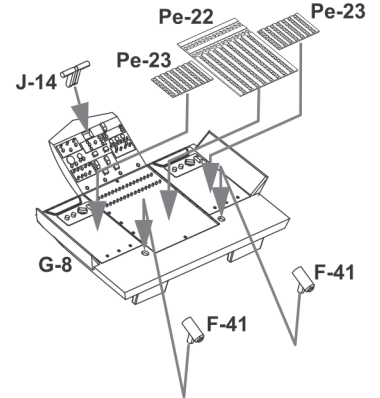

8x2

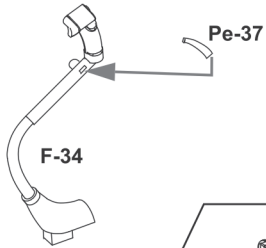

9x10

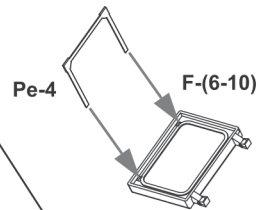

10x10

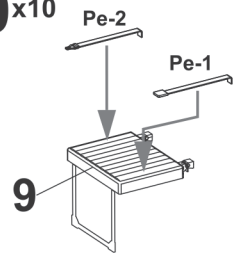

11

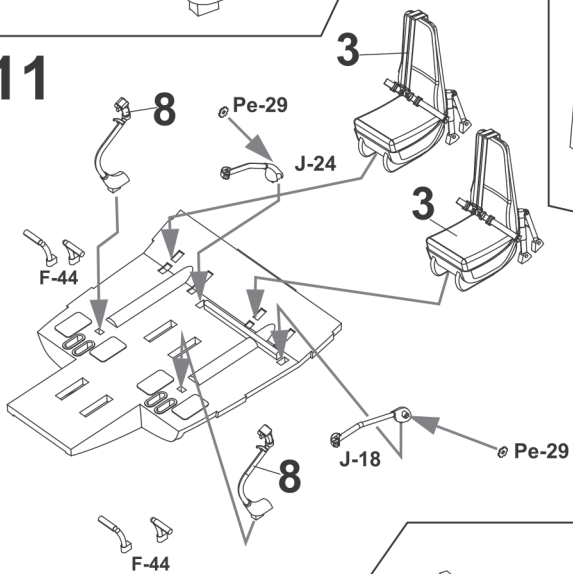

12

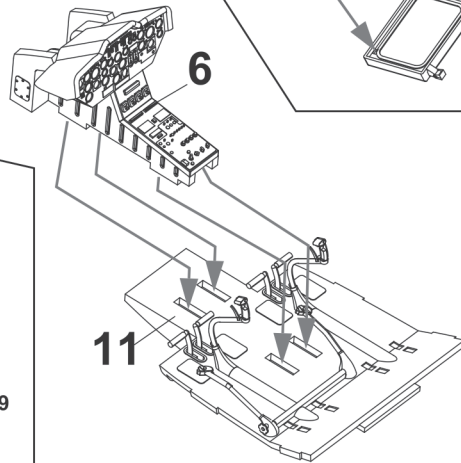

13

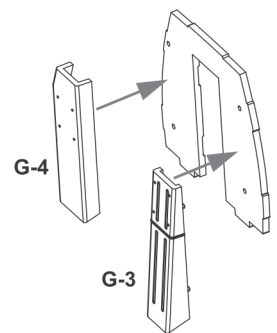

14

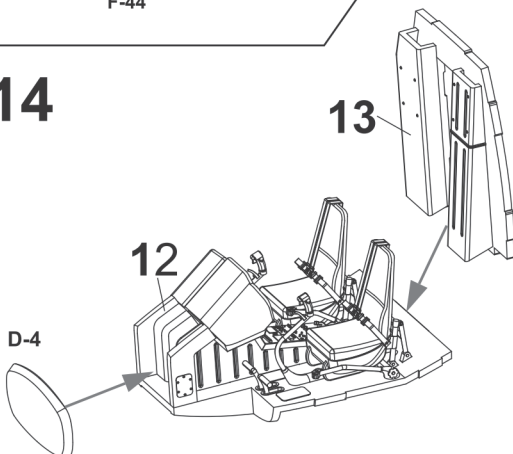

15

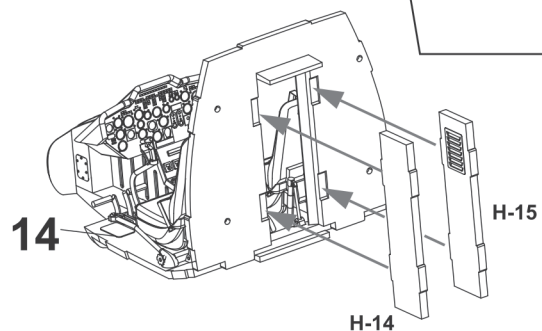

16

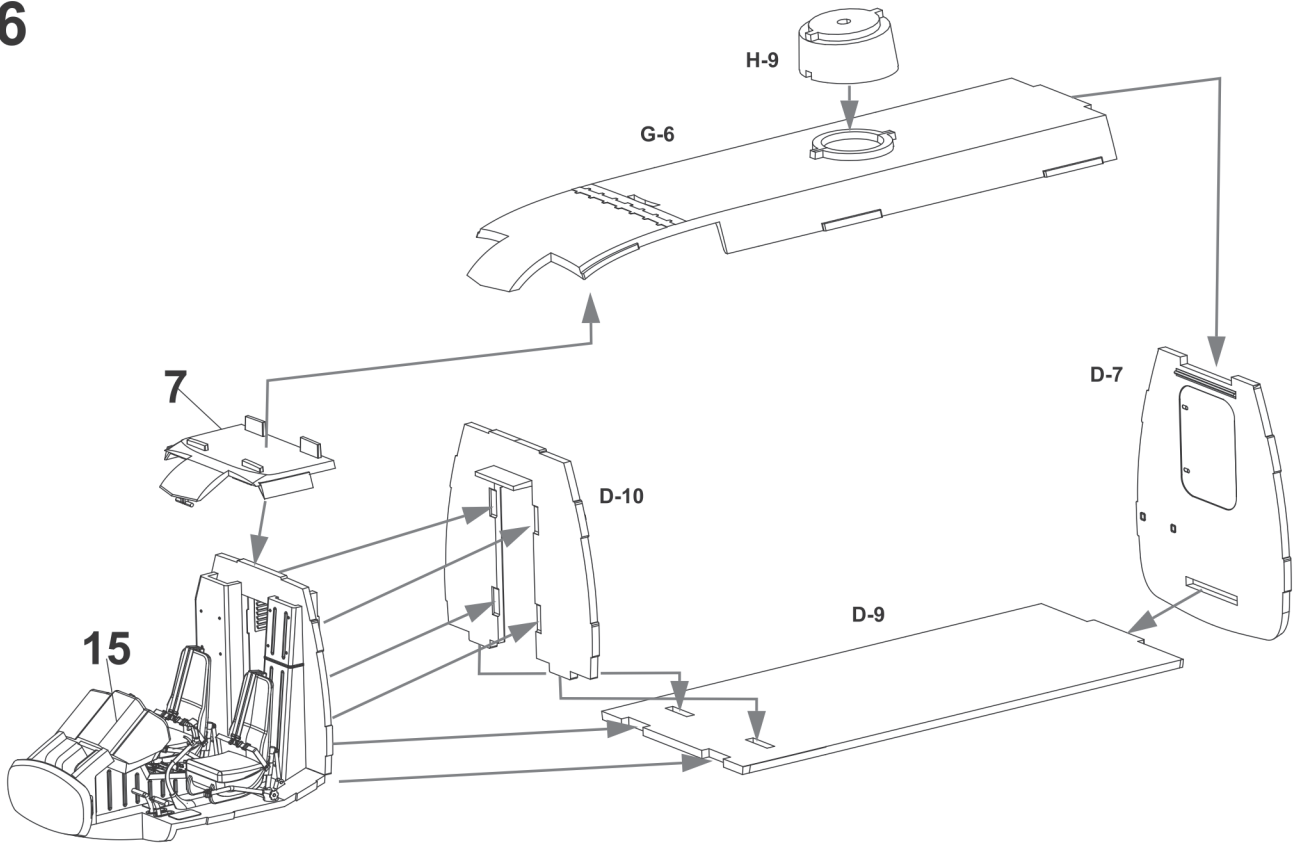

17

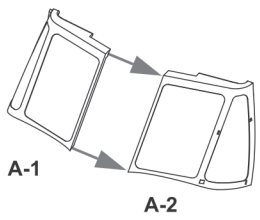

18

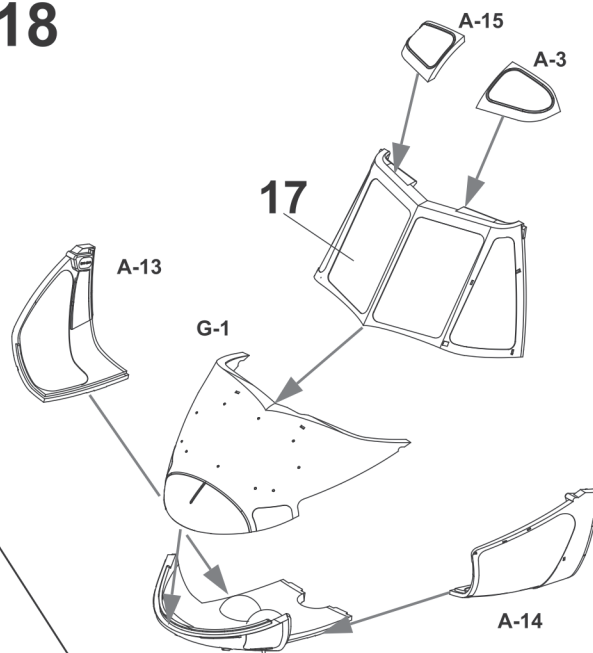

19

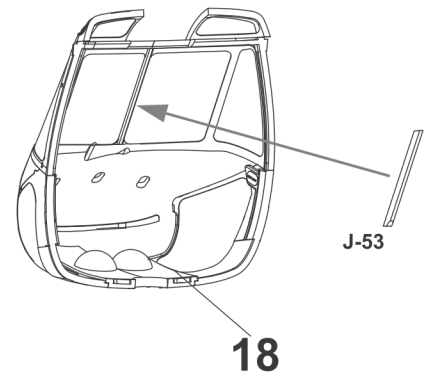

20

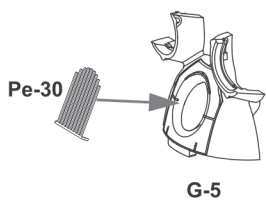

21

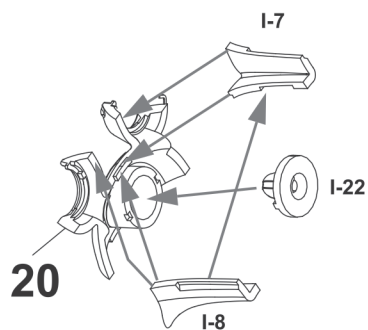

22

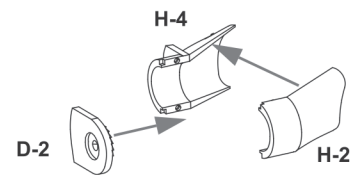

23

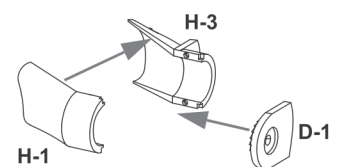

24

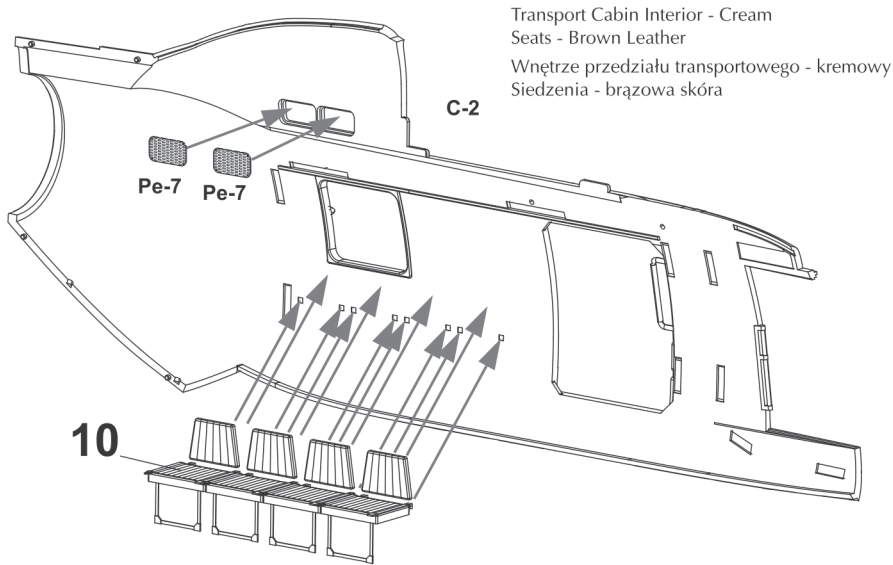

25

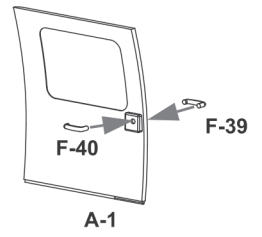

27

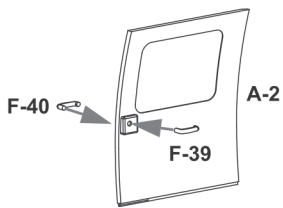

26

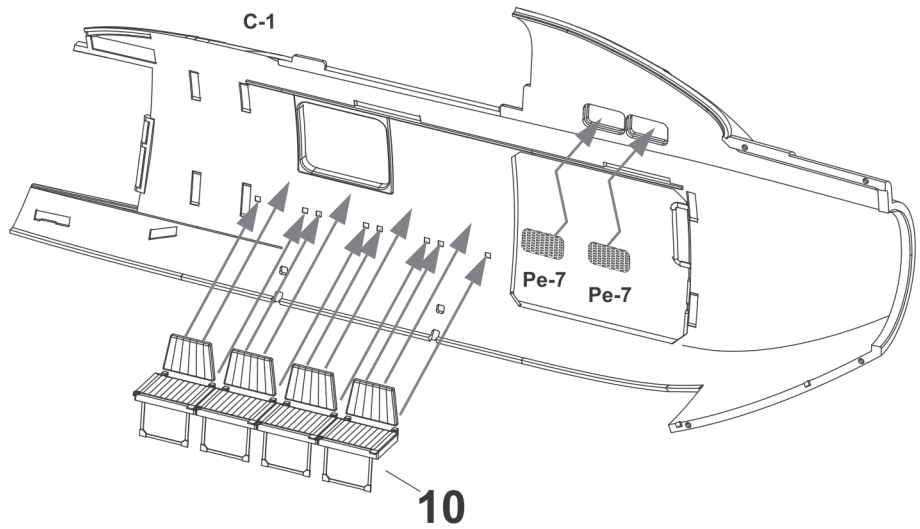

28

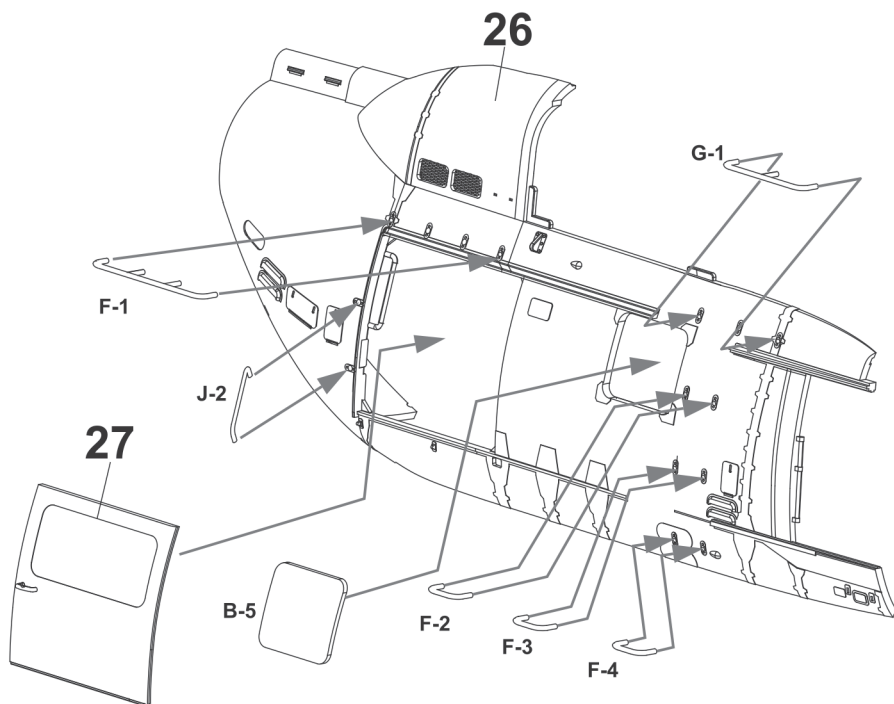

29

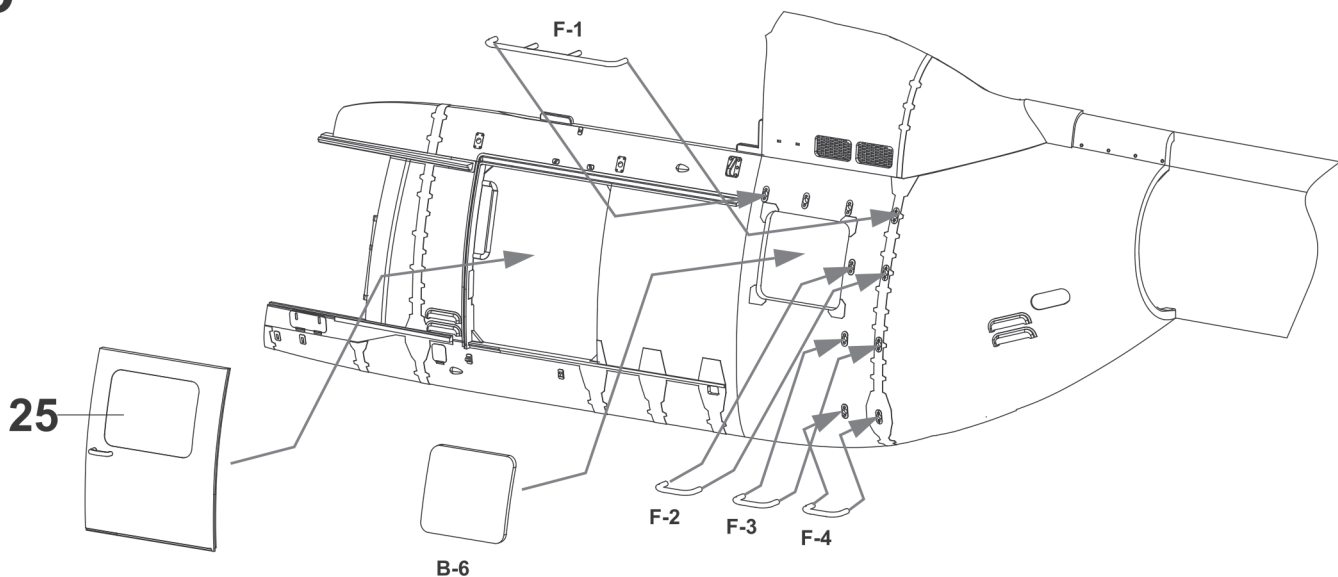

30

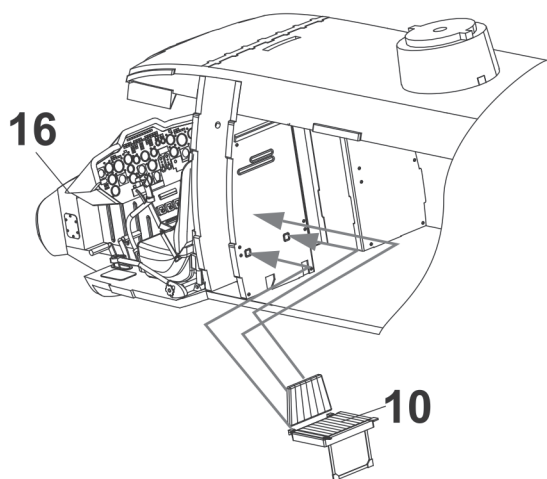

31

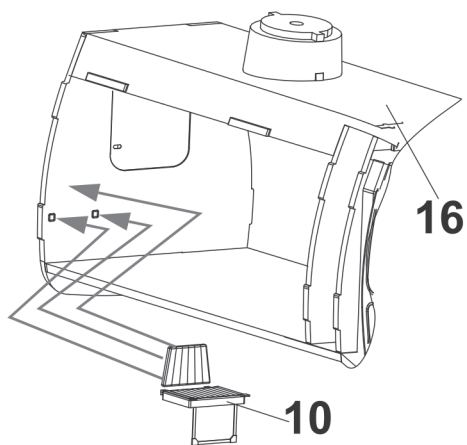

32

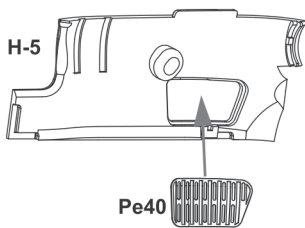

33

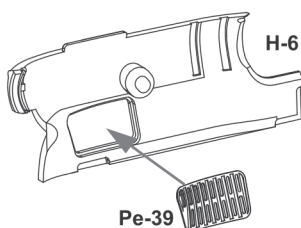

34 x2

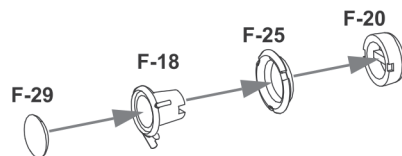

35

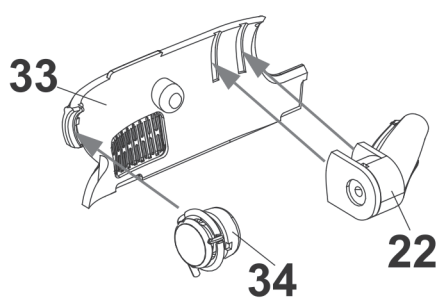

36

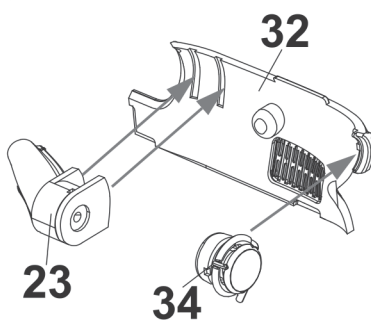

37

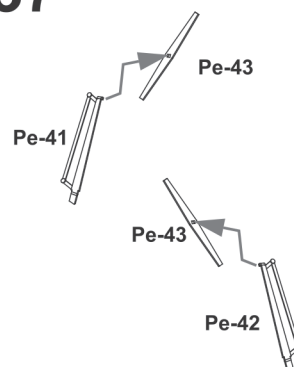

38

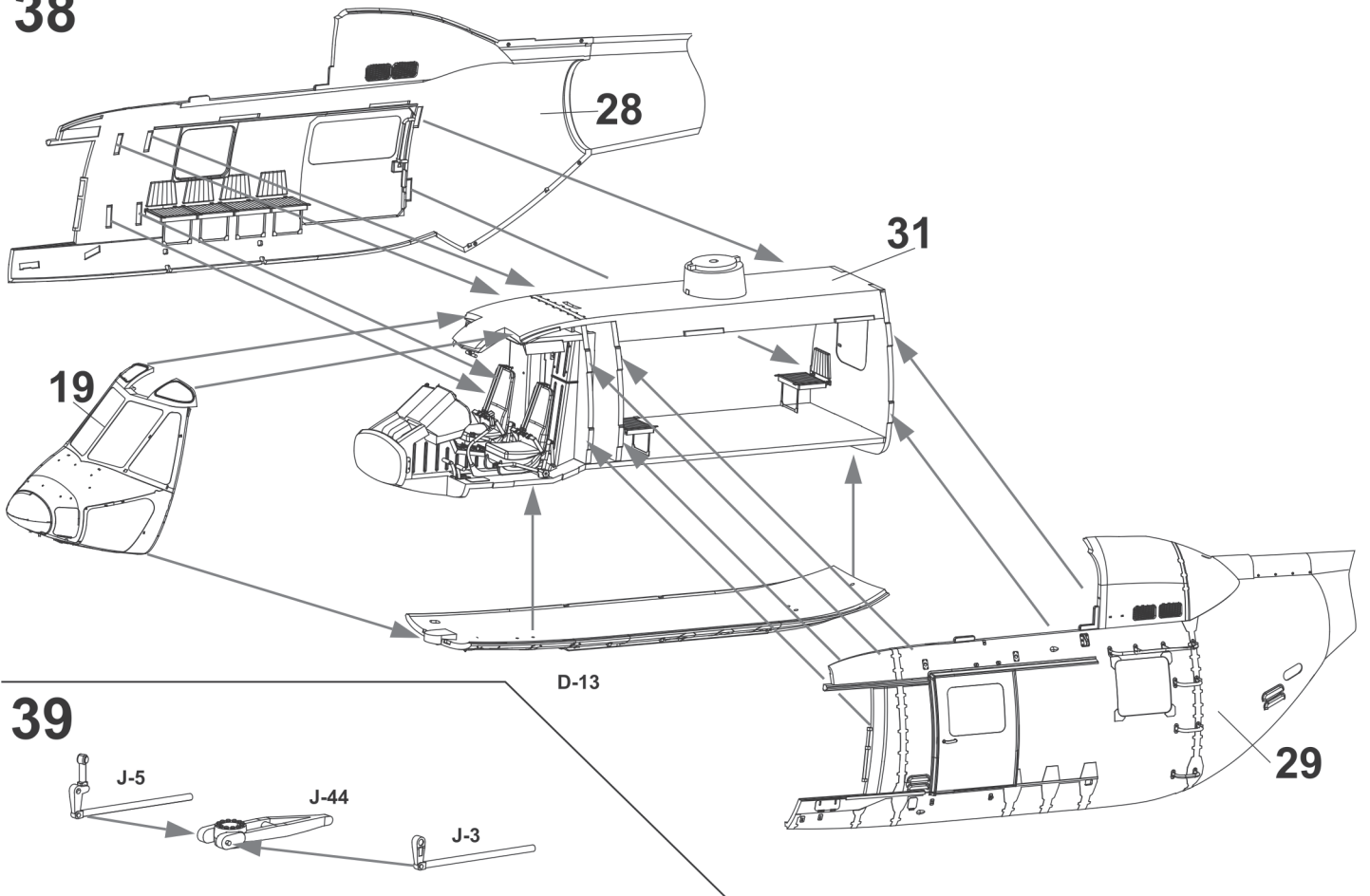

39

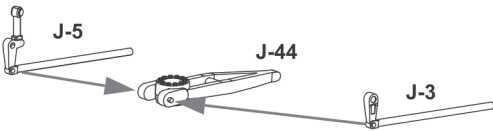

40

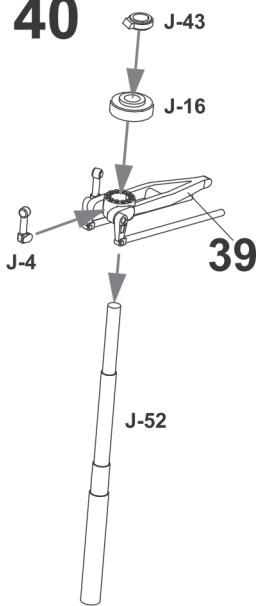

41

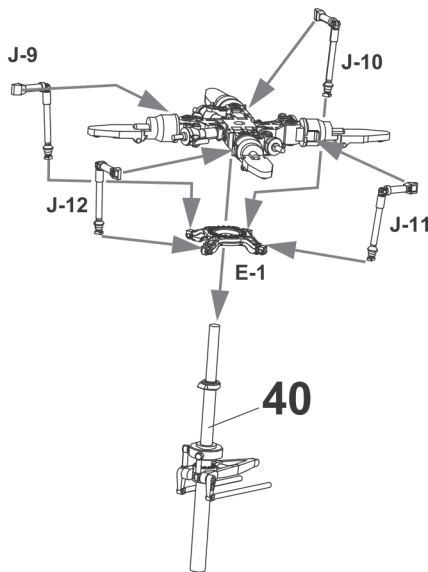

42

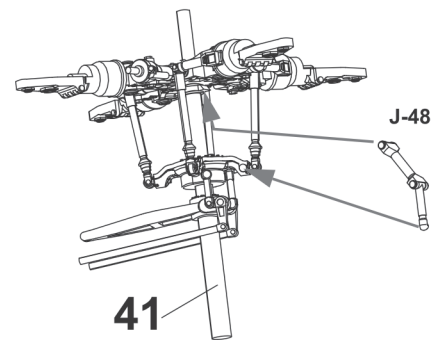

46

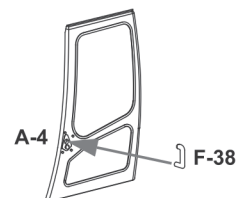

43

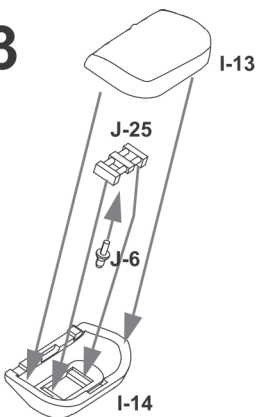

44

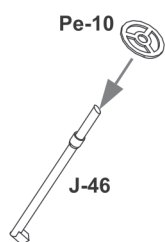

45

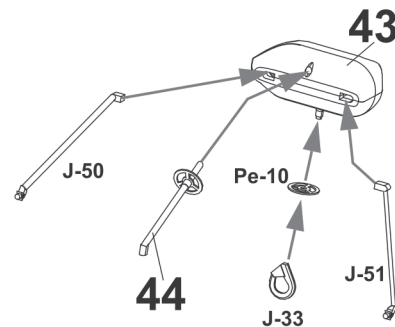

47

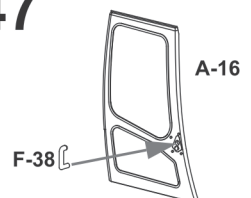

48

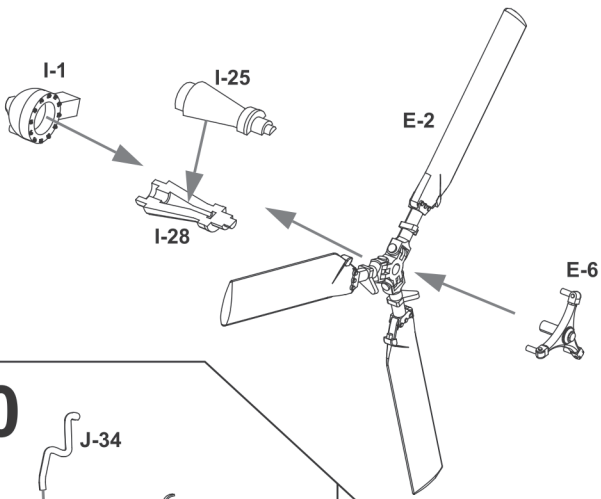

49

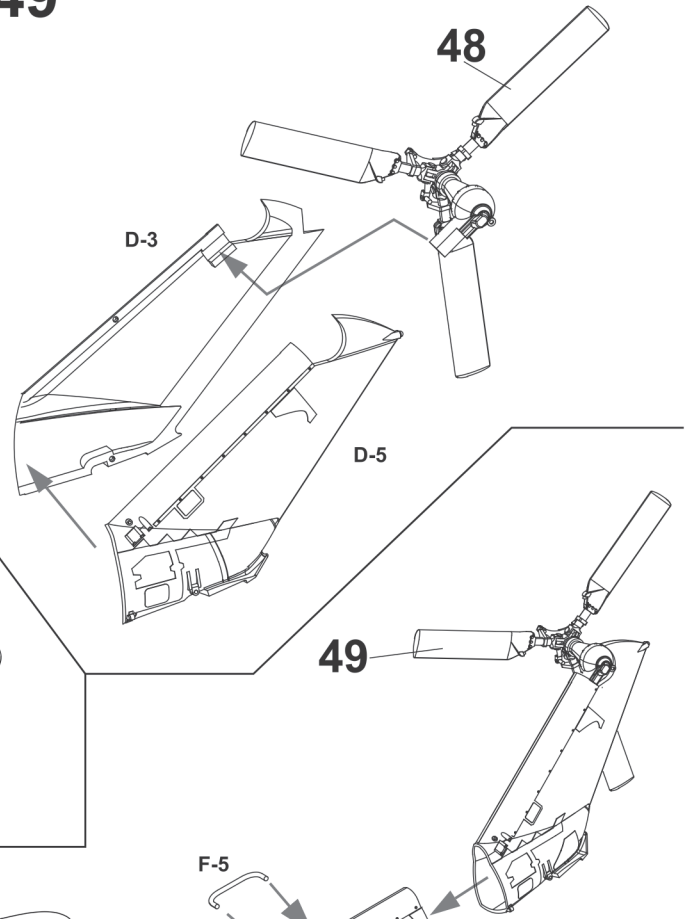

50

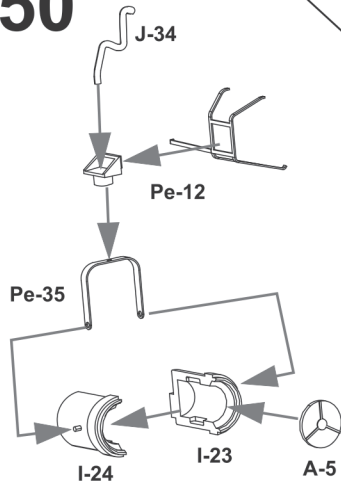

51

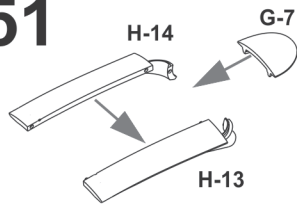

53

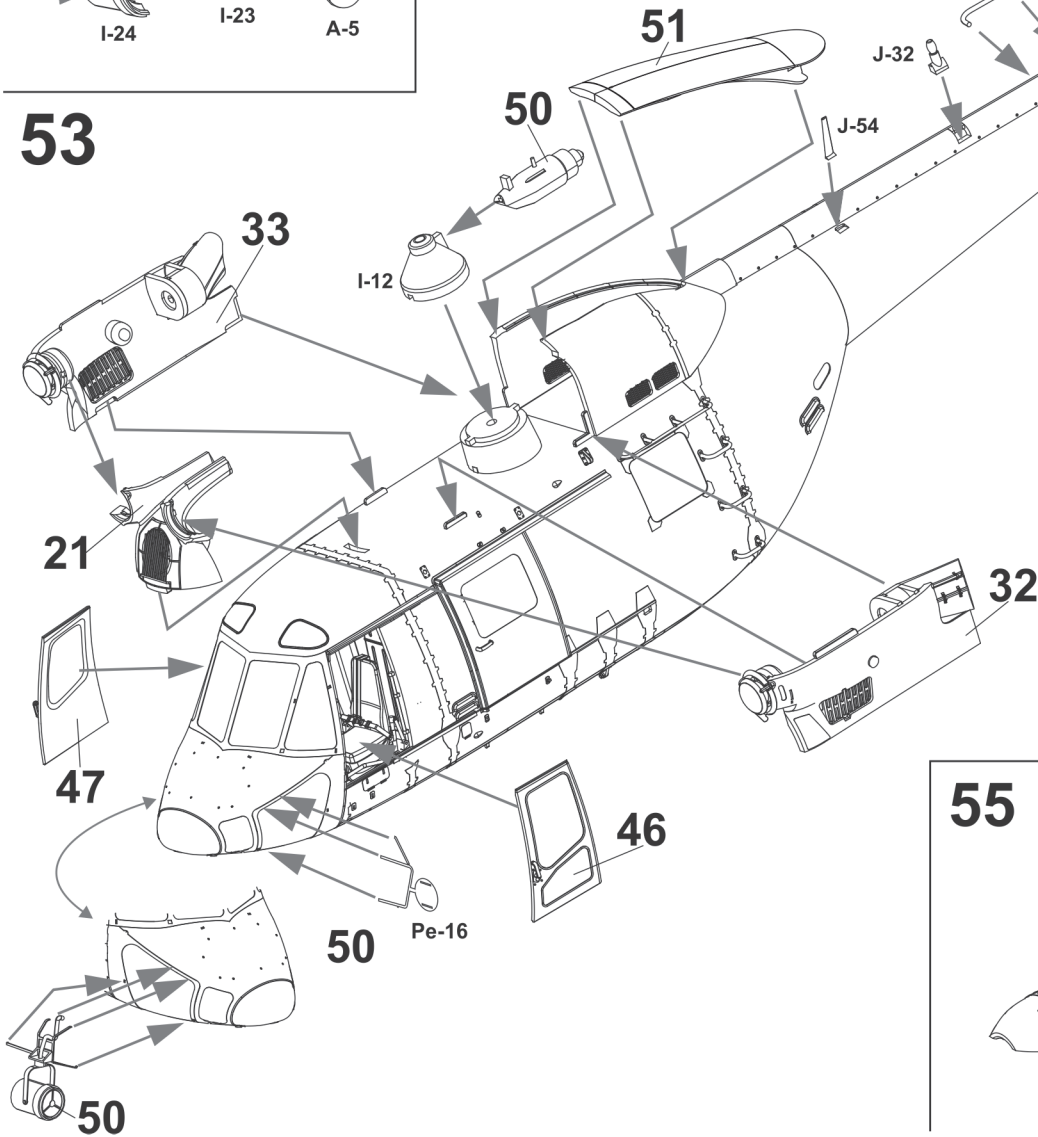

54

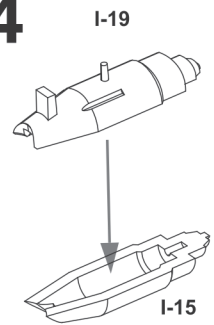

55

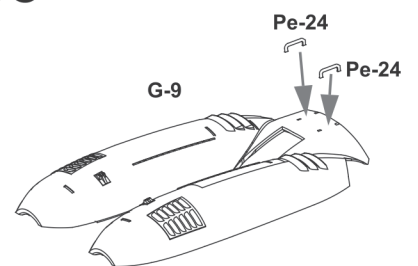

56

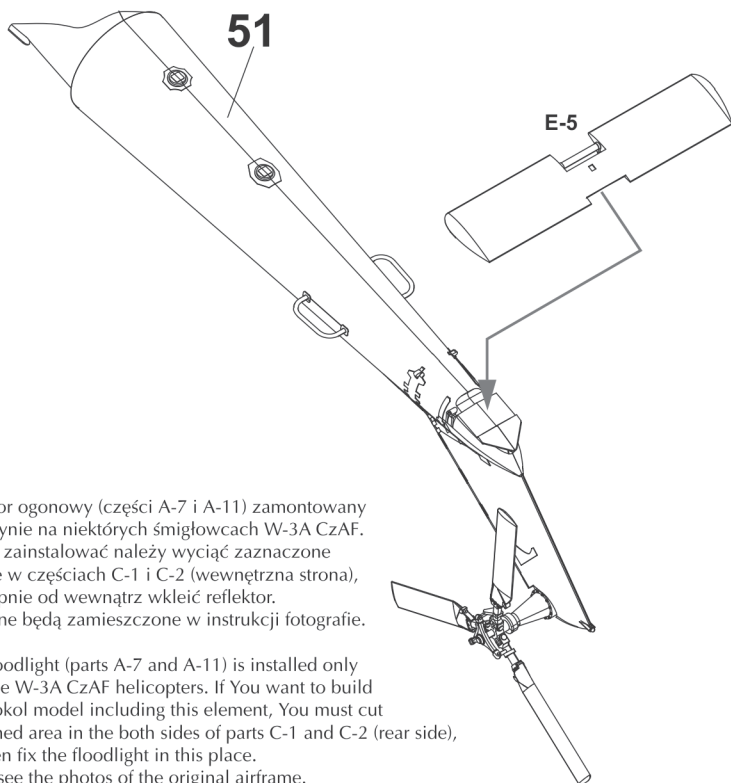

Reflektor ogonowy (części A-7 i A-11) zamontowany jest jedynie na niektórych śmigłowcach W-3A CzAF. Aby go zainstalować należy wyciąć zaznaczone miejsce w częściach C-1 i C-2 (wewnętrzna strona), a następnie od wewnątrz wkleić reflektor. Pomocne będą zamieszczone w instrukcji fotografie.

Rear floodlight (parts A-7 and A-11) is installed only on some W-3A CzAF helicopters. If You want to build Your Sokol model including this element, You must cut out thinned area in the both sides of parts C-1 and C-2 (rear side), and then fix the floodlight in this place. Please see the photos of the original airframe.

55

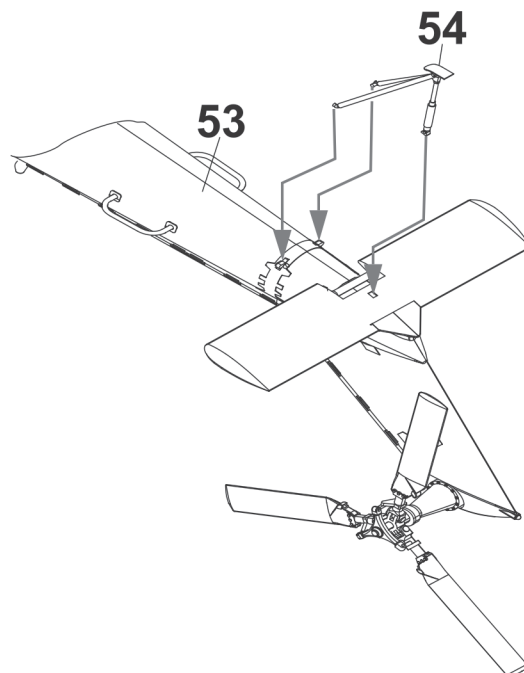

54

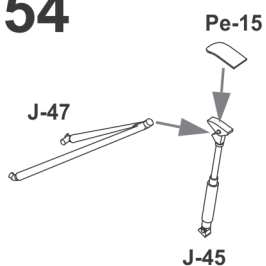

57

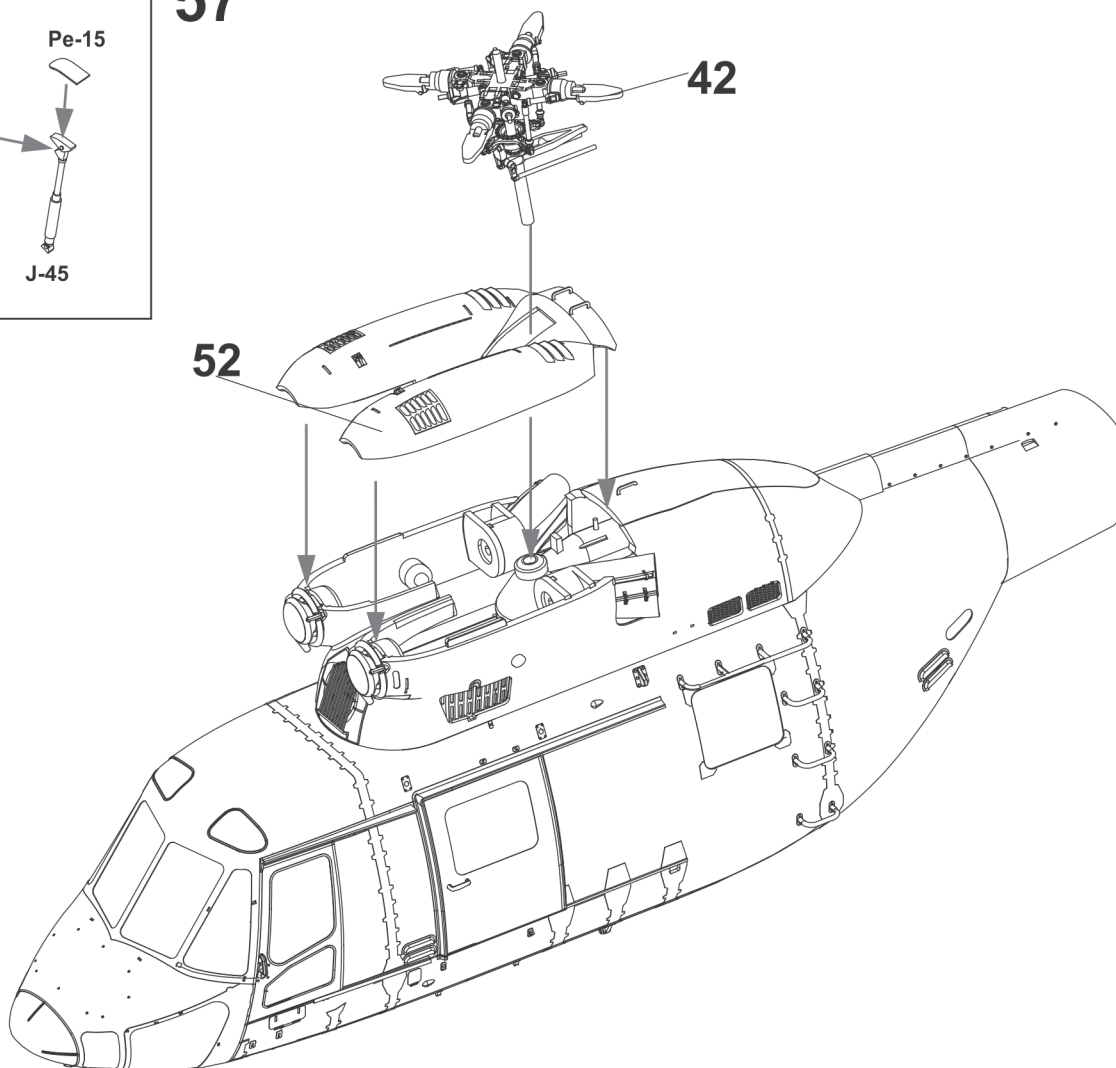

58_{x2}

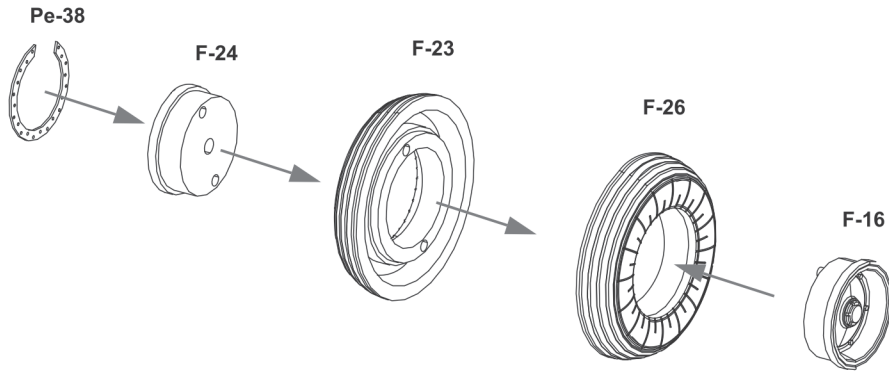

59

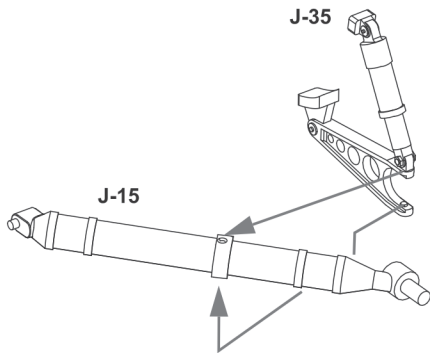

60

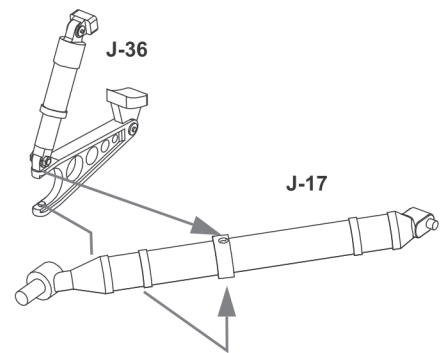

61

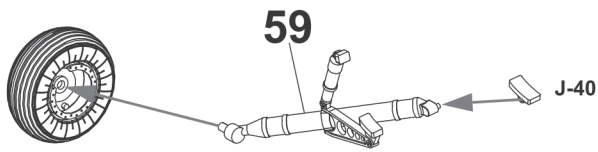

62

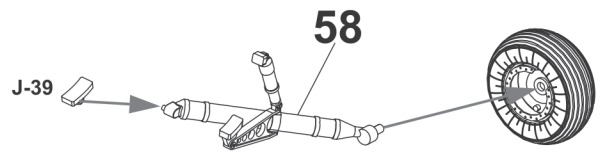

63

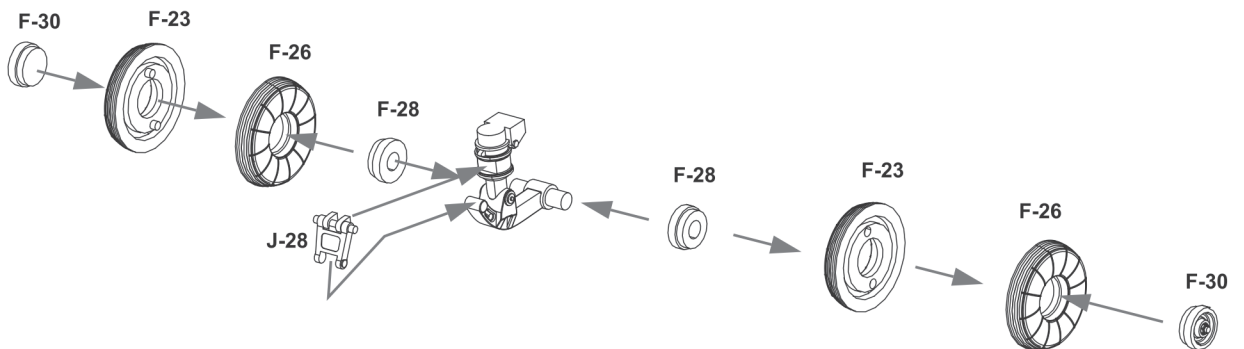

64



65

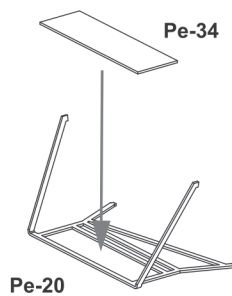

66

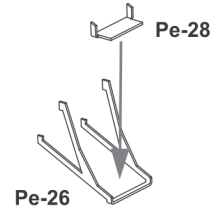

67

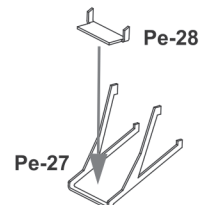

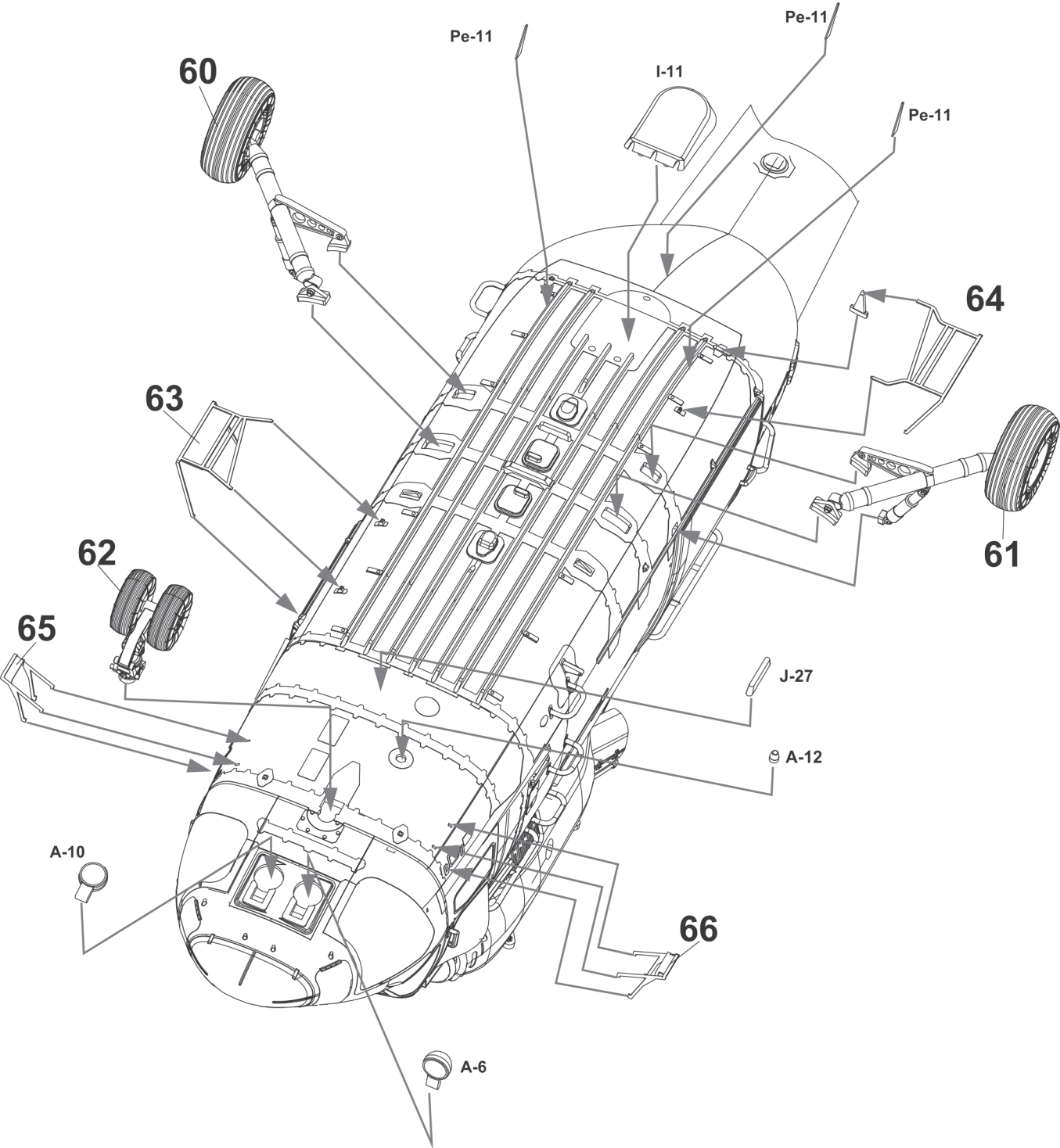

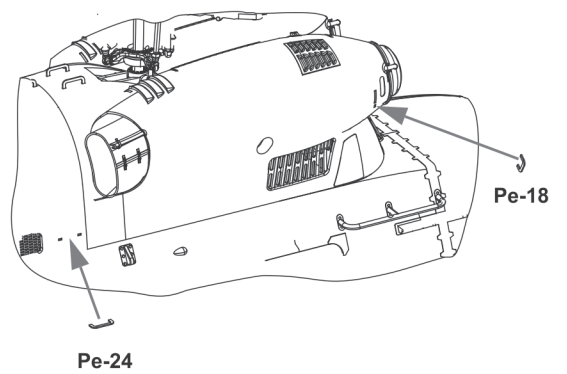
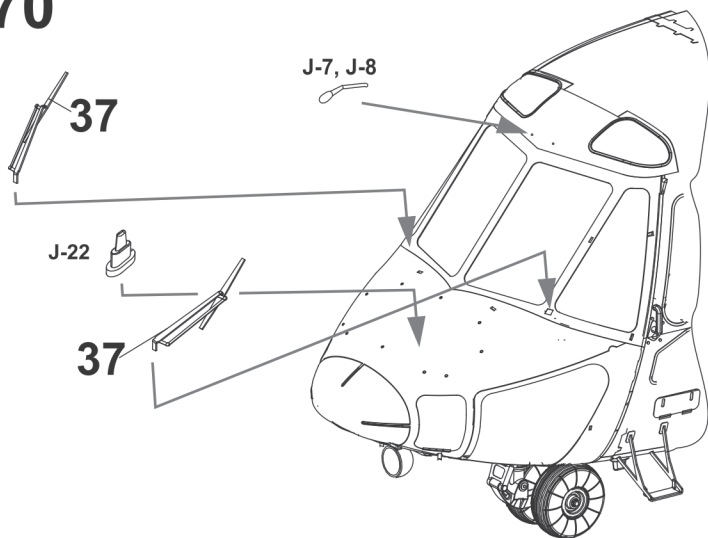
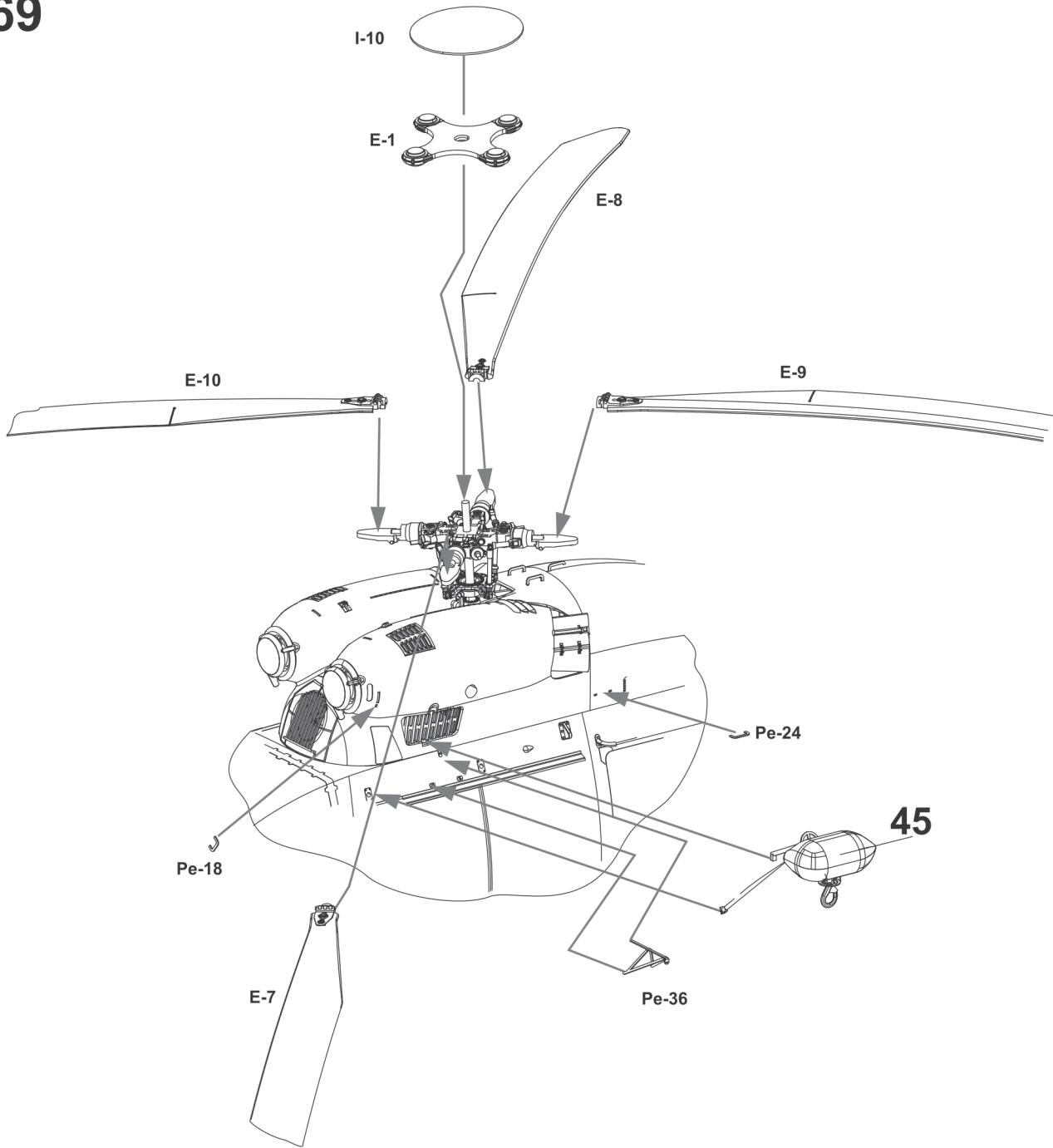

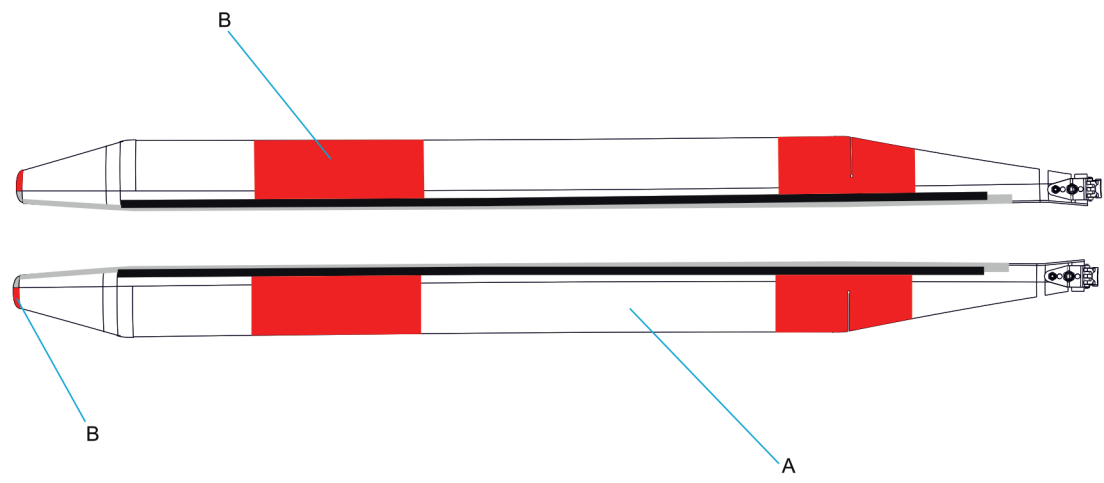
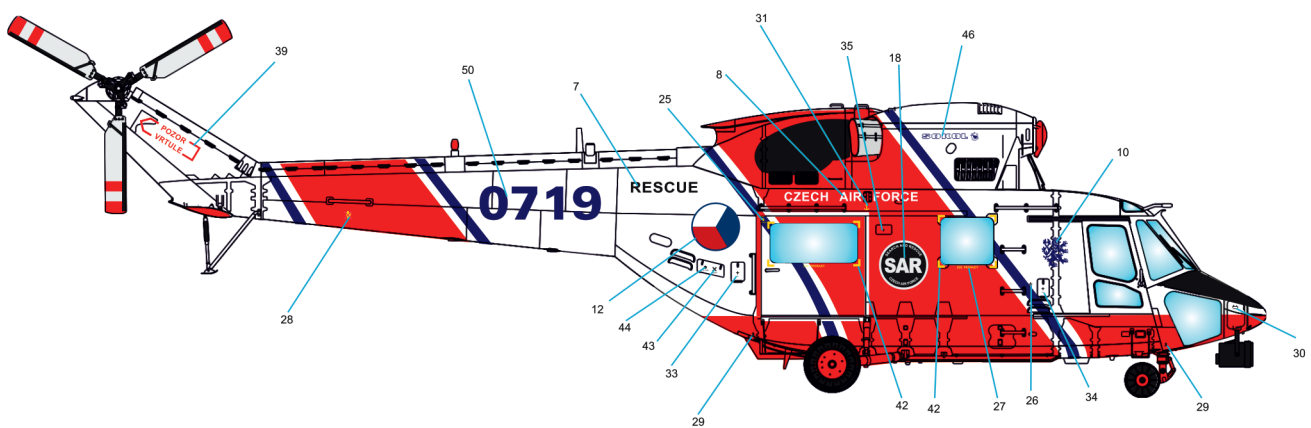
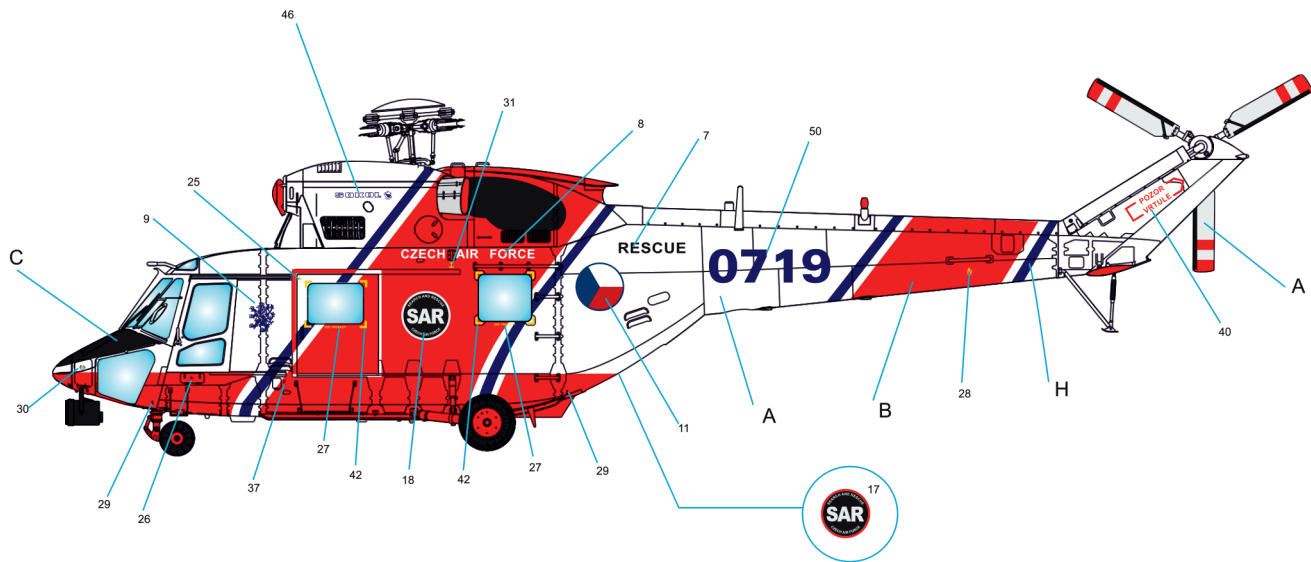

Adamek

Foto: Jan Tomek



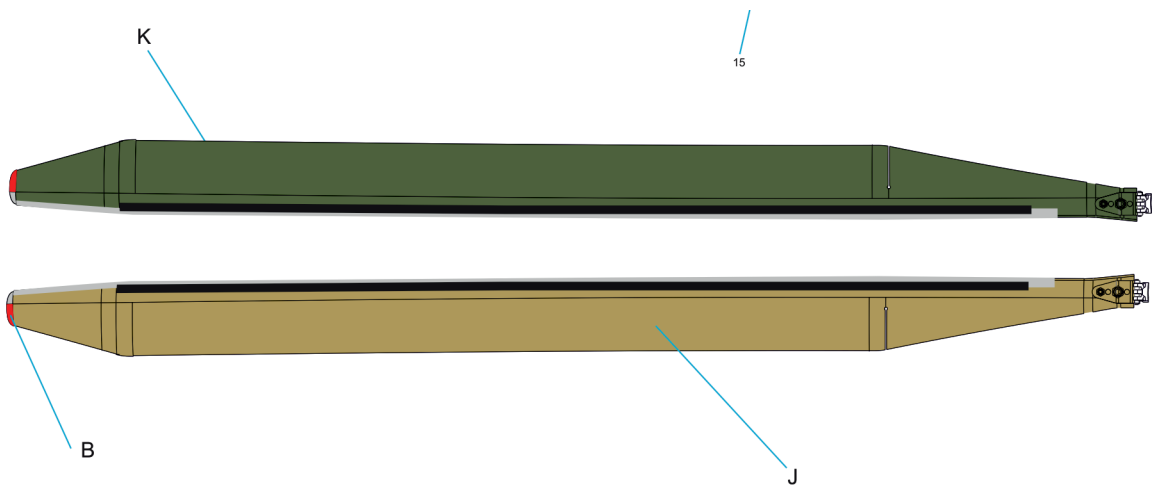

Adamek

W-3A 0718 and 0719

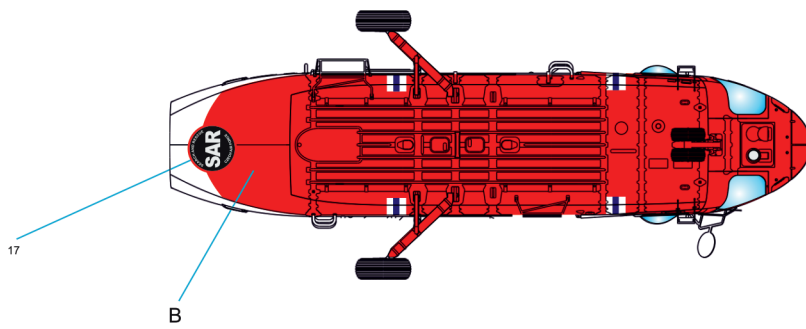

AA48002 PZL W-3A Sokol Czech Air Force

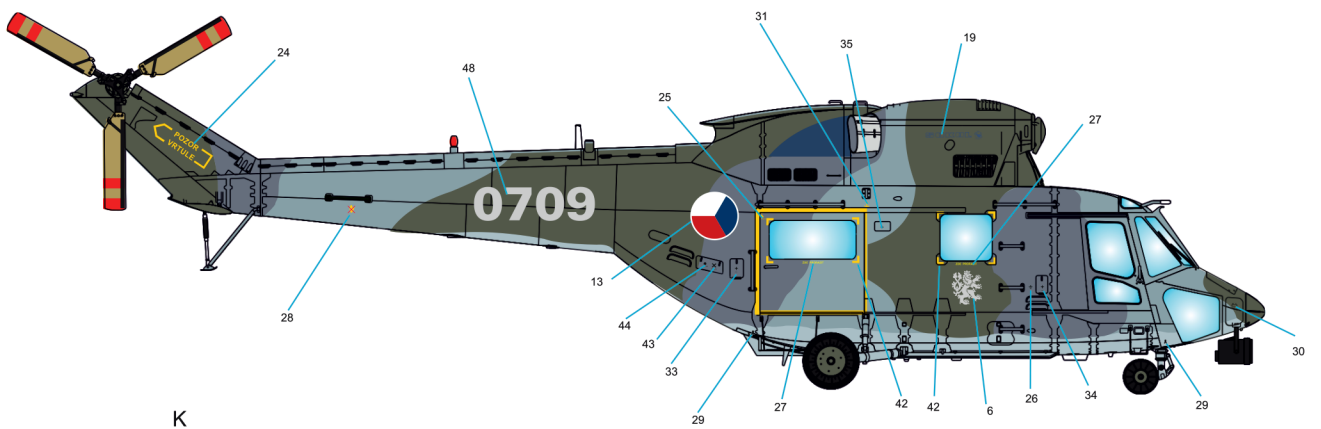
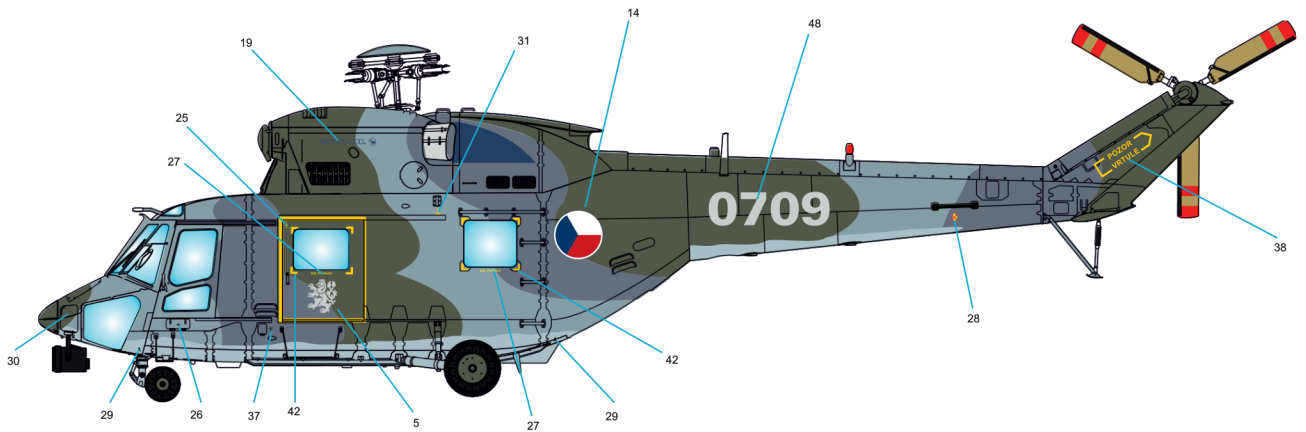

K



B

J

Adamek

W-3A 0709

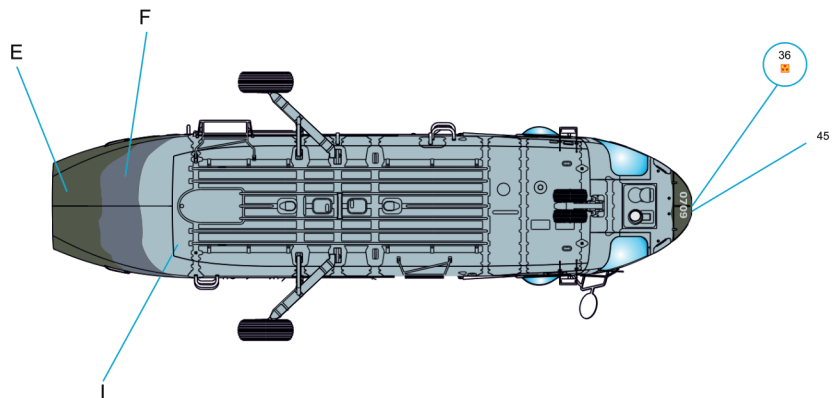

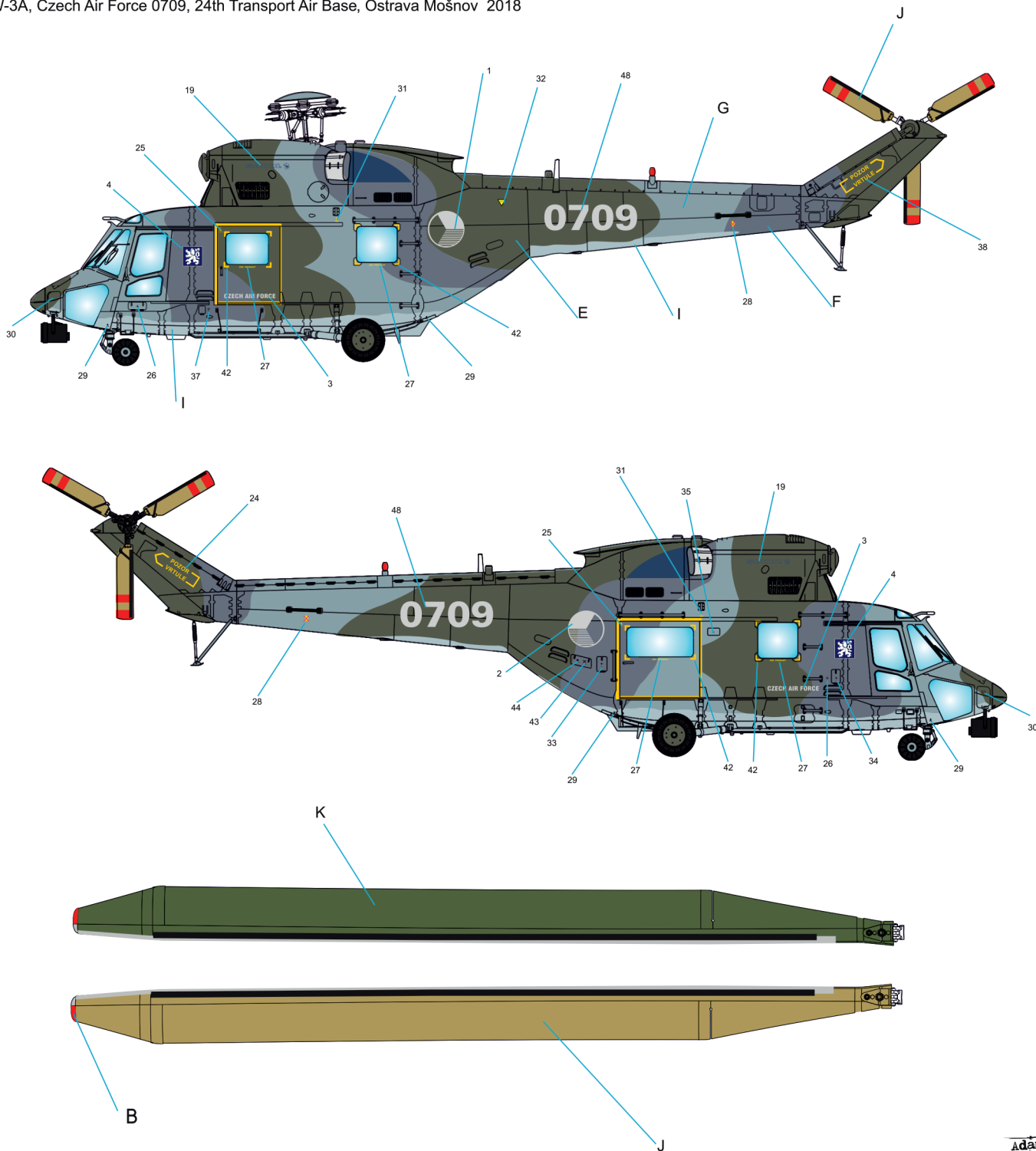

Adamek

Colors:

Tabela kolorów:

Hataka / Bilmodels / AK Real Color

A		White	HTK 101	B 051	RC004
B		FS 12197	HTK 276	B 078	RC005
C		Black	HTK 100	B 050	RC001
D		Steel	HTK 106	B 015	RC020
E		FS 34096	HTK 301	B 279	RC340
F		FS 36118	HTK 031	B 160	RC244
G		FS 36270	HTK 054	B 161	RC249
H		FS 15056	HTK 277	B 098	-
I		FS 36375	HTK 037	B 157	RC252
J		FS 20260	HTK 126	B 266	-
K		FS 24108	HTK 063	B 073	RC232

BILMODEL
PAINTS

AK **HATAKA**
HOBBY

answer
www.answerkits.pl

